

Broadband HF Antenna Matching with *ARRL Radio Designer*

Simple fixed-tuned LC networks can significantly improve the wideband input SWR of coax-fed antenna systems. Here's a report on using *ARD's* optimizer in their design.

By William E. Sabin, WØIYH
1400 Harold Dr SE
Cedar Rapids, IA 52403

Solid-state power amplifiers are usually designed to protect their output transistors by automatically limiting forward power and dc collector current.¹ Minimizing the load's SWR helps to assure that the maximum *true* power is delivered with minimal transistor heating. Reducing the load reactance is especially helpful. This article shows how to use the optimization feature of the *ARRL Radio Designer* program² to design a *fixed-tuned* (set and forget) π network that does an optimal job of reducing the SWR that a power amplifier (PA) "sees" across a large part, perhaps all, of a ham band. This concept of improving as much as possible, while not perfecting, an impedance match over a frequency band is the essential idea behind broadband impedance matching.^{3,4,5,6} The idea of inputting *lists* of frequencies, goals and measured impedance values ($R+jX$) versus frequency is a modern approach this article uses.

The Circuit We'll Adjust

Figure 1 illustrates the problem. A set of antenna feed line input-impedance values,

measured (using a noise bridge or other instrument) as accurately as possible at several frequencies across a ham band, is required. We then plug these values into an *ARRL Radio Designer* circuit-description file (*netlist*) and use the optimizer to crank out the circuit values for a matching network.

Because *ARRL Radio Designer* is an analysis, not synthesis, program, it cannot look at a matching problem and suggest a particular network type— L versus π versus π - L , for instance—over another. The network's form must therefore be coded into the netlist before optimization. Because the resonant π network is versatile—it can transform to higher or lower impedances, and has adjustable selectivity—I suggest it as a starter. At times, the optimizer may shrink one of the π 's capaci-

tors to 0 pF, leaving us with an L network. In effect, this allows the optimizer to (somewhat) modify the network topology on the fly. The user may want to try other LC topologies that may be easier to get working—for example, a high-pass π network, or one of many other bandpass types. Ingenuity can devise a multitude of options, many of which are mentioned in the works cited at notes 3 and 4.

Two Optimization Examples

In Example 1, we'll optimize the π network to match a 20-meter antenna system with a fairly low input SWR to about $50\ \Omega$ —a modest improvement that will be appreciated by PA transistors. Figure 2 graphs the system's input SWR with and without the optimized network. Let's walk through the circuit description (Table 1) to

¹Notes appear on page 36.

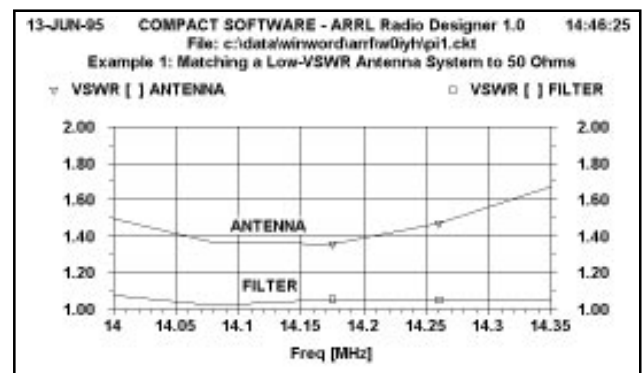
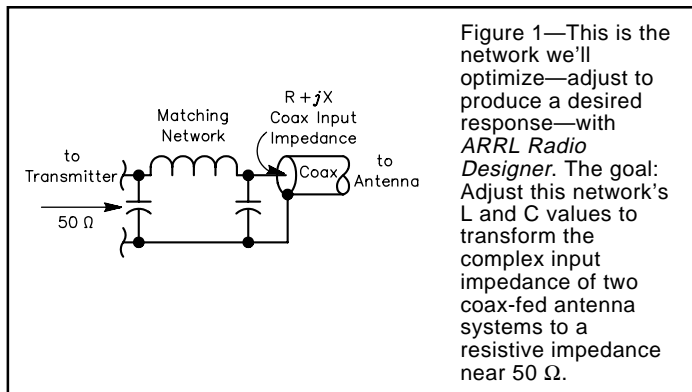

Figure 2—Tamed by the installation of a π network optimized and broadbanded by *ARRL Radio Designer*, the 20-meter system exhibits an input SWR below 1.1 from 14.0 to 14.35 MHz. (**ANTENNA** trace [upper, with triangle marker]—network absent; **FILTER** trace [lower, with square marker]—optimized network present.) Beginning with C and L values chosen according to the $20\text{-}\Omega$ reactance guideline (see text), this result was achieved after 5000 iterations of random optimization followed by 8 iterations of gradient optimization, and reflects an error function of approximately 35.

Table 1
ARRL Radio Designer Netlist for Broadband π -Network Matching

```

BLK
SHO 1 2
ONE 2 0 ZL
ANTENNA:1POR 1,0
END

BLK
CAP 1 0 C=?10PF 526PF 5000PF?
IND 1 2 L=?0.05UH .225UH 500UH?
CAP 2 0 C=?10PF 526PF 5000PF?
ONE 2 0 ZL
FILTER:1POR 1,0
END

FREQ
14.000MHZ
14.080MHZ
14.175MHZ
14.260MHZ
14.350MHZ
END

OPT
FILTER
RZ11=50 IZ11=0 W=1
RZ11=50 IZ11=0 W=1
RZ11=50 IZ11=0 W=1
RZ11=50 IZ11=0 W=1
RZ11=50 IZ11=0 W=1
END

DATA
ZL: Z
65.65 -17.06
66.57 -7.19
67.58 3.26
68.55 13.13
69.60 23.64
END

```

Table 2
Sample OPT Block for Broadband π -Network Matching with Different Goal Weightings

```

OPT
FILTER
RZ11=50 IZ11=0 W=.05
RZ11=50 IZ11=0 W=.5
RZ11=50 IZ11=0 W=.01
RZ11=50 IZ11=0 W=.5
RZ11=50 IZ11=0 W=.5
END

```

see what's going on.

- The first circuit block (ANTENNA) bypasses the π network and represents the antenna system all by itself. The SHO (short circuit) element provides the “through” connection from Node 1 to Node 2. Analyzing and plotting the performance of this block shows us the SWR at the coax input, with no matching network.

- In the ANTENNA block, the phrase ONE 2 0 ZL indicates a one-port black-box element (ONE) network whose impedance (Z) values appear in the ZL list in the netlist's DATA block. These values are given in R+jX form at the example's various (in this example, five) frequencies.

- The second block, FILTER, defines the π network to be optimized. It uses another ONE 2 0 ZL statement to terminate the network with the antenna system's input impedance. Question marks bracket the L and C values the optimizer can modify, as in C=?10PF 1303.42PF 5000PF?. The values are *constrained*—limited to pre-defined maximum and minimum values—to keep their values within the realm of the practical, and to keep the optimizer on track when it's switched between random and gradient optimization. The center (nominal) value in each constraint specifies the optimizer's starting values. We will see later how these values are chosen.

- The FREQ block lists the frequencies (again, five) at which ARRL Radio Designer will analyze the netlist's circuit blocks.

- The OPT block gives the name of the circuit to be optimized (FILTER), and also lists, in ascending frequency order, goals for each optimization frequency. In this case, we want the real part of FILTER's input impedance, RZ₁₁, to be 50 Ω , and the imaginary part, IZ₁₁, to be 0.0 Ω , at all five optimization frequencies. (ARRL Radio Designer does not allow the specification of optimization goals in terms of SWR.) This list also contains *weighting* factors, W, for use by the optimizer. More about this later.

- The DATA block lists, in ascending frequency order, the R+jX impedance measurements made at the input of the antenna-system coax. The label ZL links this data with the ONE elements in the FILTER and

ANTENNA circuit blocks.

Note the one-to-one correspondence between the FREQ block entries, the ZL data-set lines and the goal statements in the OPT block. This relationship allows the optimizer to directly map the antenna system's measured performance to the corresponding optimization goals even though no frequencies are specified in the ZL data and OPT-block goal statements. The optimizer automatically relates the first FREQ entry with the first line of ZL data and the first OPT goal statement, and so on. No additional description of the optimization problem is necessary for proper optimizer operation.

This format can be used (with caution) as a *template* for a variety of problems in which load impedances and corresponding goals can be listed by frequency. For example, the goal data could be the complex conjugates of a set of complex generator impedances. The network would then be optimized to provide an improved conjugate match to these generator impedances. I have used this approach successfully.

One major difficulty is to be sure that the optimization found is the best possible one (a *global minimum* in the optimizer's *error function* as opposed to a *relative* or *local minimum*). To ensure this, I use the following procedure:

1. For starting network component values, use the L and C values that have 20 Ω of reactance at *f*, the center of the band over which optimization is desired. These values may be found by the equations

$$L = \frac{20}{2\pi f} \text{ and } C = \frac{1}{20 \cdot 2\pi f}$$

where *f* is the band-center frequency in hertz, L is inductance in henries, and C is capacitance in farads.

2. Although the OPT block states goals in terms of RZ₁₁ and IZ₁₁, monitor your progress by plotting SWR for the ANTENNA and FILTER one-ports. (As is appropriate to its RF-engineering heritage, ARRL Radio Designer uses the term *VSWR*—voltage standing wave ratio—instead of SWR.)

3. Before running the optimizer, analyze the circuit and plot a preliminary SWR graph for ANTENNA and FILTER. Use ARD's **Window | Tile** command (with **Tile**

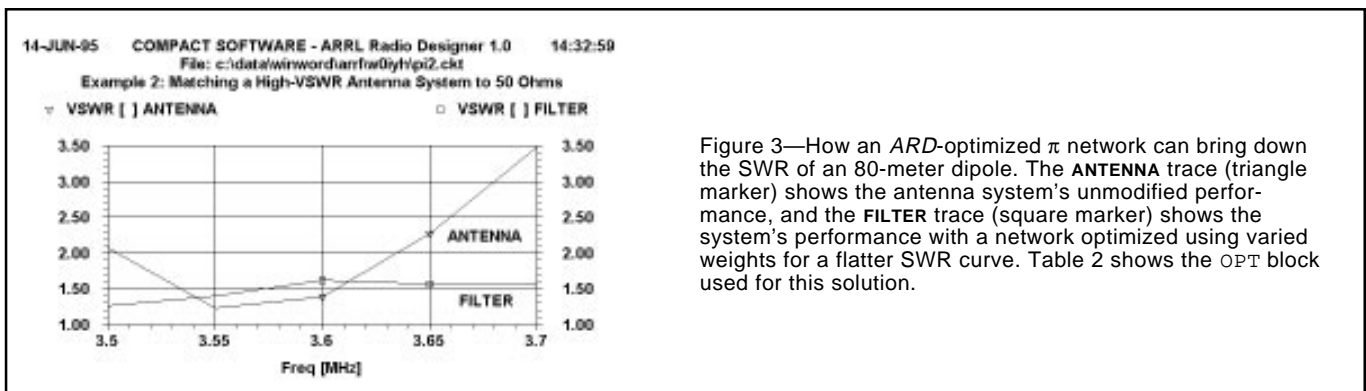

Figure 3—How an ARD-optimized π network can bring down the SWR of an 80-meter dipole. The ANTENNA trace (triangle marker) shows the antenna system's unmodified performance, and the FILTER trace (square marker) shows the system's performance with a network optimized using varied weights for a flatter SWR curve. Table 2 shows the OPT block used for this solution.

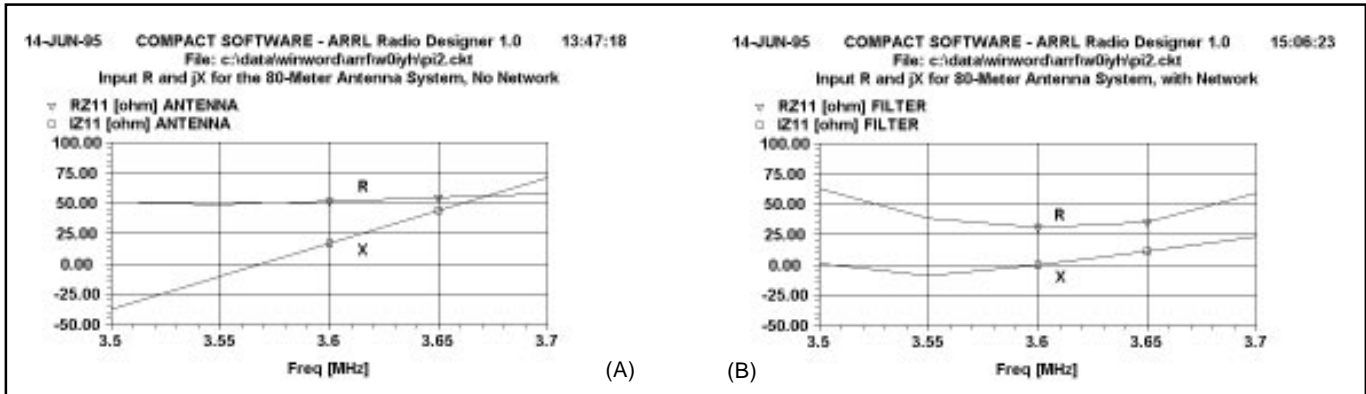

Figure 4—Plotting the resistive (R) and reactive (X) parts of the input impedances of ANTENNA (A) and FILTER (B) in Example 2 reveals that the network reduces SWR mainly by reducing reactance.

Circuit Editor turned on) to display the netlist and graph side by side onscreen.

4. Before running the optimizer, manually adjust the network's C values in equal increments (in 5% steps) and/or L value (in 1% steps), re-analyzing the circuit each time, until the π network's input SWR is fairly close to the SWR of the antenna system alone. (ARRL Radio Designer's Tune feature can simplify this procedure.) This often helps the optimizer to find an acceptable answer more quickly.⁷

5. Now we're ready to use the optimizer. Set the number of iterations to 100 or 200, select random optimization, clear the **Display** check box, and click **Optimize**. I find that it helps to watch the VSWR plots progress with the iterations, even though it slows down the process. If the optimizer is obviously on the wrong track for many hundreds of iterations and does not seem to be heading for a global minimum, it's time to consider taking action to get some progress going. More about this later. Often, too, the solution can be seen to "oscillate" endlessly back and forth; the wrong network topology, poor weighting factors and/or poor starting LC values are likely causes. (A major possibility is that we may just be trying to accomplish too much with a simple circuit.) Sometimes the convergence can be quite slow, so don't give up too quickly.

6. If you find that the FILTER VSWR plot tilts too much or has a dip or peak in its middle, try *slightly* modifying the OPT block's weighting factors. (Table 2 shows an example.) The higher the weight for a given goal statement, the greater its contribution to the optimization error function. Merely increasing a weight from 1 to 2 can make a noticeable change in the error function and the shape of the resulting FILTER SWR curve. (Using the weighting factors to get desired effects is best described as an art that only experience can teach. The technique does work, though.) Example 2 (Figure 3) shows the results of using this procedure to match a high-SWR antenna system across part of the 80-meter band.

7. Figure 4 graphs resistance and reactance (R and X) for the 80-meter system of

Example 2, with and without the compensating network in place. The resonant π network, often called a *quarter-wave filter*, is one network type that can do more than just transform an impedance's magnitude: It can also provide a reactance variation that helps to compensate for reactance variation in its load. This reduction or "tuning out" of reactance is the main means by which the network reduces SWR. The problem then is to find the optimal L and C values. This can be done analytically, but we prefer to let the ARRL Radio Designer optimizer do the work. Sometimes the high-pass version of the π network is more useful.

8. A further option is to replace the precise, nonstandard values of C that the program suggests with the nearest standard values (or the closest combination of standard values), and rerun the optimizer to determine a revised inductor value. (Be sure to remove the question marks around values you don't want optimized.) In most cases, the results will be quite acceptable. Of course, when you build a real version of a network you've modeled, the capacitors you use must have adequate voltage and current ratings. Variable capacitors can be preset with a digital capacitance meter.

9. Sometimes, the required values may be critical; networks derived with consid-

erable heroic effort are quite often value-toughy. You can get a feel for component-value sensitivity by tweaking values manually or by using ARD's tune feature. A final fine tuning of the hardware version of your network will often be helpful. Toroidal inductors can be fine-tuned by expanding or compressing the space between their turns, for instance.

9. As an option for more realistic optimization, and as a necessity if you want to realistically model your network's loss, specify realistic Qs for your network's inductors and capacitors. As a conservative rule of thumb for large Miniductor coils and toroidal coils wound on -2 cores, set your inductor's Q1 equal to 200 at an F equal to band center. This would make Example 1's inductor specification read IND 1 2 L=?0.05UH .225UH 500UH? Q1=200 F=14.175MHZ. For capacitors, set Q equal to 1000, as in CAP 2 0 C=?10PF 526PF 5000PF? Q=1000.

The Down Side

The somewhat simplistic approach I've presented has limits. If your particular matching problem seems to be hopeless, you may have exceeded the limits of what can be accomplished with a simple LC network or with broadband matching in gen-

The Challenge of Optimization

So enthusiastic are we about ARRL Radio Designer that we'd love to be able to pitch its optimizer to antenna experimenters as "your one-stop shop for all your matching needs." The reason we don't—and the reason Bill Sabin prefers that this article be taken more as fuel for experimentation and education than as a simple "how-to" piece—is that computerized circuit optimization requires experience and skills that can only be learned over time.

Even networks as superficially simple as the π or the L may require you to apply Herculean effort and many hours tweaking, analyzing, plotting, optimizing and re-analyzing to achieve an acceptable outcome—if you can find a useful solution at all. You'll benefit most from such experiences if you're willing to accept up front that manually peaking and dipping your antenna tuner's settings with the help of an SWR meter may lead to a simpler, even better, solution. But if you want to learn more about the modern technique of broadband impedance matching, ARRL Radio Designer's optimizer can be a terrific teacher.—WJ1Z

eral. If the impedance to be transformed does not vary excessively and/or abruptly across a not-too-wide band—as is true of most wire antennas—this method should be useful. You're free to try other, more complex network types, of course, but keeping in mind that *ARRL Radio Designer* is primarily a low-cost analysis, not synthesis, program, using it for broadband optimization of networks with many elements may be difficult to manage. Reducing the frequency coverage to only part of a band, as in Example 2, is a useful alternative.

The result in Example 1 was an easy one. But quite often, action must be taken to improve the results. In Example 2 (an 80-meter dipole), a folded dipole with a 4:1 impedance stepdown to 75-Ω coax, then to a corrective network to 50 Ω, would surely work over a wider bandwidth.⁸ Trying a different network may help: Experiments in matching the Example 2 antenna by optimizing a *five*-element (double- π) network showed faster convergence than the π optimizations. But when the network becomes overly complex and value-critical, it's time to rethink the problem and consider one of the many other possible approaches. This is good engineering practice.

One big problem involves the length, in wavelengths, of the coax. Although SWR is the same (or very nearly so) along the coax, the impedance ($R + jX$) varies drastically if the SWR is not 1:1. As a result, the corrective network may be very difficult to

design for some lengths of coax. A change in length, followed by more impedance measurements, may be very helpful.⁹ (*ARD* can be helpful here also. Create a file similar to Example 1, but use a TRL [*ARD* transmission line element] and terminate it with a ONE characterized by the ZL data. Plot the TRL's input impedance [RZ_{11} and IZ_{11}]. Adjust the TRL's length to get RZ_{11} and IZ_{11} values that might be easier to work with.) But if the job can be done economically and with reasonable effort, the result is an improved interface between the solid-state PA and antenna over a wider frequency range. This is a worthy endeavor, especially for contest operating, and an intellectual challenge.

Acknowledgment

I thank David Newkirk, WJ1Z, for his contributions to this article. Dave's expertise with *ARD* is greatly appreciated.

Notes

¹Robert Schetgen, KU7G, editor, *The ARRL Handbook for Radio Amateurs*, 1995 edition (Newington: ARRL, 1994), pp 17.62 and 17.93.

²*ARRL Radio Designer* (order #4882) is available from ARRL Publication Sales (203-594-0200, fax 203-594-0303) for \$150 plus shipping—*Editor*. See the ARRL Publications Catalog in this issue.

³Thomas R. Cuthbert, "Broadband Matching Methods," *RF Design*, Aug 1994, pp 64-71.

⁴Thomas R. Cuthbert, "Broadband Impedance Matching—Fast and Simple," *RF Design*, Nov 1994, pp 38-50.

⁵W. E. Sabin and E. O. Schoenike, *Single-Side-*

band Systems and Circuits, 2nd edition (New York: McGraw-Hill, 1995), chapters 16 and 17.

⁶*The ARRL UHF/Microwave Experimenter's Manual* (Newington: ARRL, 1990), chapter 12.

⁷A brute-force approach that may work in some cases is to turn the optimizer loose for 5000 or 10,000 iterations of random optimization—after turning off Display to speed the process—before intervening manually or switching to gradient optimization. For this approach to work, the values of optimizable components must be constrained to a sufficiently wide range of practical values, as shown in the Table 1 netlist's FILTER block. (During random optimization, the optimizer can increase *unconstrained* values—optimizable values specified by just one value within question marks, such as ?526PF?—from 0 to no more than twice their specified nominal values. If random optimization is then selected and the solution value happens to be more than double the specified nominal, the optimizer will stall short of a solution. *Constrained* optimizable values—values specified in the form ?10PF 526PF 10000PF?—afford considerable flexibility because they work well in both gradient and random optimization.) Many times, however, active user participation in an optimization—steering, weighting adjustment, or even reengineering the problem—will be necessary for success.—*Editor*

⁸Rudy Severns, N6LF, "A Wideband 80-Meter Dipole," *QST*, Jul 1995, pp 27-29.

⁹If you can measure your antenna's $R + jX$ right at its feedpoint (with the feed line disconnected), a matching network designed and installed to do broadband matching at that position is a much better solution. Doing so would properly terminate the line, allowing it to operate at a low SWR, minimizing its loss, and making the impedance seen at its station end independent of its length. **QST**